

Lerner Robotic Arm

Engineering Calculations Summary Report

Cole Pace: Project Manager and Prototype Lead

Joel Gisleskog: Research Lead

**Caleb Lamca: Manufacturing Lead, Co Design Lead, and
Fundraising Lead**

Kaitlyn Davis: Finance Lead and Documentation Lead

**Colin Donnellan: Development Lead, Co Design Lead, and
Testing Lead**

Fall 2025-Spring 2026



Steve Sanghi College of Engineering

Project Sponsor: Dr Zachary Lerner

Faculty Advisor: Dr. Dante Archangeli

Instructor: Dr David Willy

1.0 Introduction

Strokes are the leading cause of upper limb disability; survivors often report loss of mobility in one arm which limits daily use. The goal of the project is to create a hip mounted robotic arm that will help rehabilitate the upper limb mobility. This report will summarize and update all calculation work that has been done up to this date, providing a comprehensive account of the standards, processes, and methods that have been used through the analysis.

2.0 Top Level Design

Below is an updated version of the Top-Level design. Included in the image are leader lines linked to part numbers and descriptions in the Bill of Materials on the right side. There are 3 subsystems in the model, accounting for 7 unique parts, as well as an additional 6 standalone parts, and 54 pieces of fasteners and hardware. This is the third iteration of the model, featuring a completely reworked design consisting of machined carbon fiber square tubing, 3-D printed carbon fiber reinforced nylon parts, machined carbon fiber plates, machined aluminum hinge sub assembly, modeled end effector components and sub assembly, and optimized geometries.

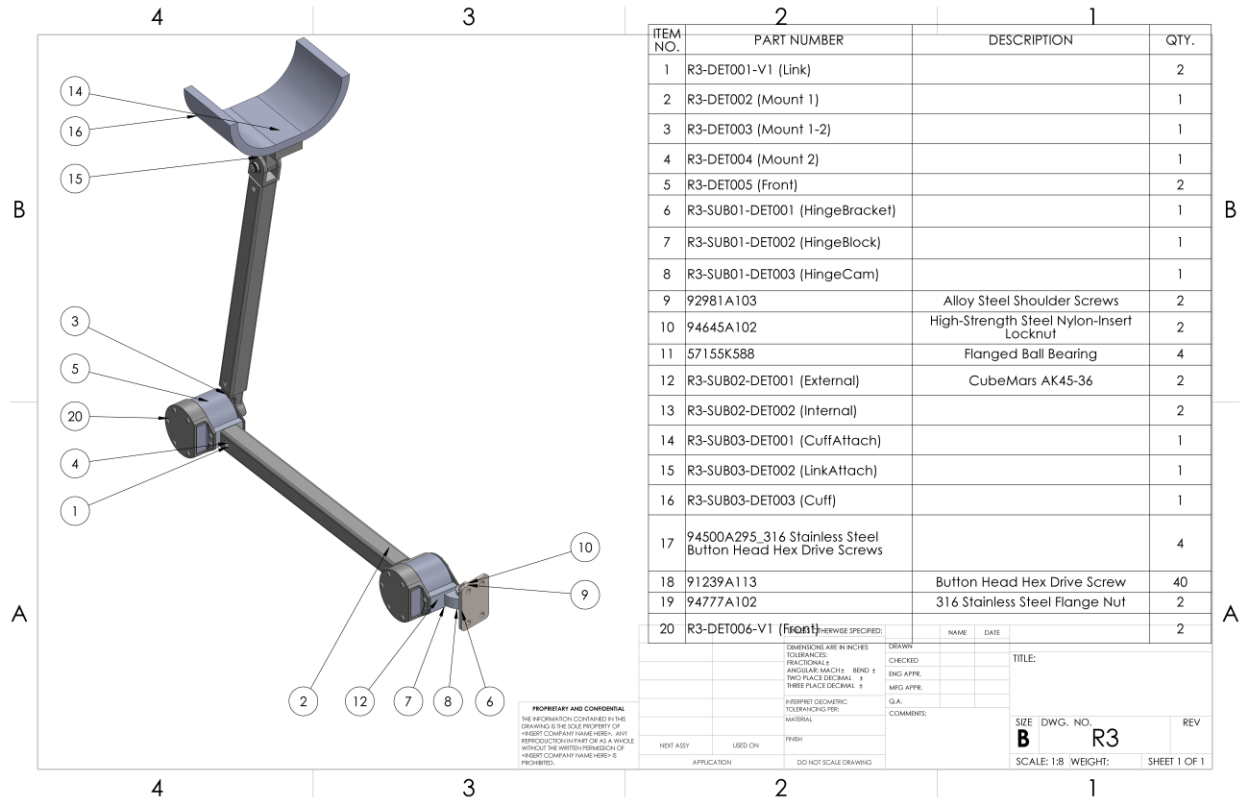

Figure 1: Top-Level Design

1.1.a Customer Requirements

- a. The primary customer requirements for the wearable robotic arm were identified through discussion with the project sponsor, Dr. Zach Lerner, and analysis of the target users (stroke survivors with limited upper-limb mobility). The most critical requirements are Range of Motion and Safety, both rated highest in importance. This device must allow natural arm movement while supporting the elbow through active gravity compensation. Safety ensures that the user is protected from excessive joint torque, pinch joints, or electrical hazards during operation. Comfort and Ease of use are also key factors, as the device will be worn for extended periods and must not restrict the user's daily activities. A Low-Profile design ensures minimal obstruction and promotes confidence in public use, while Durability guarantees long-term reliability under repeated mechanical loading. Lastly, Cost is considered to maintain affordability for both research and potential clinical applications.

1.1.b Engineering Requirements

- b. The engineering requirements translate the customer's needs into quantifiable design targets that can be measured and verified. The robotic arm will feature 3 Degrees of Freedom (DoF) to allow natural arm and elbow motion while supporting necessary rehabilitation movements. To maintain comfort and reduce fatigue, the total system Weight is constrained to under 2 kg, with mass distributed near the waist to minimize user load. Torque Speed performance will target 60°/s to match realistic human joint motion speeds during lifting tasks. For endurance, Battery Life is specified to exceed 8 hours, ensuring the device can function for an entire therapy session or daily use period without frequent recharging.

- c. Manufacturability and material quality are also defined quantitatively. Manufacturing Cost must remain below \$1,000, and both Component and Material Quality are rated at engineering levels suitable for safety and mechanical integrity under load. Additionally, Degrees of Freedom, Weight, and Torque Speed correspond directly to user comfort, range of motion, and ease of use, while Battery Life and Durability influence reliability and long-term satisfaction. These parameters provide concrete targets for design validation and testing, ensuring each engineering decision supports the primary customer objectives. The quantified metrics serve as performance benchmarks for prototype evaluation and future optimization.

1.2 House of Quality (HoQ)

		Degrees of Freedom													
		Quality of Components	pos							Correlation					
		Quality of Materials		neg							Positive	pos			
		Manufacturing Cost	pos		pos							Negative	neg		
		Torque Speed		pos											
		Battery Life	neg	pos		neg	pos								
		Weight	pos	pos	pos	pos	pos	pos							
Relative Weight (%)	Customer Weights	Customer Requirements	Engineering Requirements							Benchmarking					
			Degrees of Freedom	Quality of Components	Quality of Materials	Manufacturing Cost	Torque Speed	Battery Life	Weight	Poor	Adequate	Excellent			
11	4	Comfortable	3	3	3	1	3	3	9		C	AB			
22	5	Range of Motion	9	3	3	1	1	1	1	A	B	C			
10	5	Safety	3	9	9	1	9	1	3			ABC			
10	2	Cost for Consumer	3	9	9	9	3	3	3	AC	B				
5	3	Durability	1	9	9	1	1	1	9		B	AC			
5	4	Ease-of-use	9	3	3	1	9	3	3	BC	A				
22	3	Low-Profile	3	1	3	3	3	9	9	ABC					
Technical Requirement Units			N/A	\$	\$	\$	0 / 3	Hours	lbs						
Technical Requirement Targets			4	<1400	<1000	<1000	60	>8	<2						

Figure 2: House of Quality

3.0 Summary of Standards, Codes, and Regulations

The following are **standards** that will be implemented in our design process and are inspired by the World Health Organization’s Standards for Prosthetics and Orthotics [1].

1. Safety and Risk Management (Relevant standards: 21, 22, 49, 60)
 - a. No exposed pinch points
 - b. Emergency stop feature
 - c. Current and torque limits as well as software safety.
 - d. Clear failure modes for when power dies.

2. Documentation and Knowledge Transfer (Relevant standards: 13, 57, 59, 60)
 - a. Clear wiring diagrams.
 - b. Code comments explaining what and why
 - c. Known issues and limitation list

3. Modularity and Upgradability (Relevant standards: 16, 24, 46)
 - a. End effector/linkages should be swappable
 - b. Sensors should be replaceable

- c. No permanent design choices that block upgrades
4. Reproducibility and Repeatability (Relevant standards: 51, 57, 60)
 - a. Motion is as expected within a designated tolerance.
 - b. Defined test routines to ensure functionality
 5. Clear Use and Limits for the Device (Relevant standards: 4, 37, 51)
 - a. Defined and enforced payload limits
 - b. Defined joint limits in both hardware and software
 - c. State the intended and unintended function of the device
 6. Data and Experimentation Support (Relevant standards: 13, 23, 57)
 - a. Log joint angles, torques, and errors
 - b. Easy access sensor data
 - c. Exportable datasets for documentation

The **regulations** that are most closely related to our device were identified in 21 CFR part 890, Physical Devices under the limb orthosis section [2]. Applicable FDA regulations define classification and scope but do not provide quantitative performance requirements such as joint speed, torque, or acceleration. The FDA, however, provides regulations for medical devices in general, and the following are pertinent to our design.

1. Design Input Verification [3]
 - a. Design input requirements should be clearly defined and capable of validating through objective evaluation methods, including analysis, inspection, or testing. Each requirement should specify a representative method for verifying compliance with intended use.
2. Quantitative Specifications with Tolerances [4]
 - a. Numerical design inputs must include explicit measurement tolerances to guide accurate fabrication and allow reviewers to objectively assess conformance.
3. Electrical Safety and Electromagnetic Compatibility [5].
 - a. Devices must limit leakage current and avoid shocks.
 - b. Must be resistant to EM interference that could alter movement or control.
 - c. Battery-powered arms must meet safe charging and discharge standards.
4. Software as a Medical Device / Control Software [6].

- a. All software controlling motors or sensors must be validated.
- b. Must handle fault conditions safely.
- c. Version control, traceability, and documentation are required.

4.0 Summary of Equations and Solutions

4.1 Battery Load Analysis (Colin Donnellan)

The battery has been selected being 1800mAh 6S 22.2V 50C LiPo Battery and two of them will be used in parallel to increase the capacity the battery can have. Then, using the specifications of the AK45-36 motor to calculate the run time that the current battery setup could produce. The specifications used from the motor are rated current (2 amps) and rated voltage (24 volts). Below are the equations and solutions to the run time found in the current setup.

$$Run\ Time = \frac{Battery\ Voltage \cdot Battery\ Capacity}{Number\ of\ Motors \cdot (Rated\ Voltage \cdot Rated\ Current)} \cdot 60 \quad (1)$$

$$Run\ Time = \frac{22.2\ V \cdot 1.8\ Ah}{2 \cdot (24\ V \cdot 2\ A)} \cdot 60 \approx 25\ min$$

This has right now shown that the current battery setup is lacking compared to what the goal of runtime is. The goal of runtime is 8 hours, so the 50 minutes calculated is far from the desired time. The main reason believed for this is that the calculated time is continuous runtime, which would not be the case in the project. The true runtime with more natural movement pattern, as people are normally not moving their arms for 50 minutes straight, will be found when testing is done to see its true runtime.

4.2 Link Position Analysis (Joel Gisleskog)

A design requirement given by the client is for the users' arm to be able to comfortably rest by their side. Therefore, the angular velocity of the links was calculated to move the arm from resting position to extended in front of the users' body within a specific amount of time. Starting off, the Pythagorean theorem was used to find the coordinates of the resting position.

$$link\ 1 = link\ 2 = 248mm$$

$$\sin(\theta) = \left(\frac{opp}{hyp}\right) \quad (2)$$

$$\sin^{-1}\left(\frac{70}{248}\right) = 16.4^\circ \quad (3)$$

$$90 + 73.6 = 163.6^\circ$$

$$l_1x_1 = l \cdot \cos(\theta) = 248 \cdot \cos(163.6) = -237.9mm \quad (4)$$

$$l_1y_1 = l \cdot \sin(\theta) = 248 \cdot \sin(163.6) = -70mm \quad (5)$$

$$B_{x1} = -237.9 + 248 = 10.1mm$$

$$B_{y1} = -70 + 0 = -70mm$$

$$A_s = (-238mm, 70mm)$$

$$B_s = (10mm, 70mm)$$

Now that the coordinates of the links at the rest position have been found, the final position coordinates must be found. The final position will create an angle of 45° for both motors having the 45° angle from the waist to the elbow.

$$l_1x_2 = l \cdot \cos(\theta) = 248 \cdot \cos(45^\circ) = 175.36mm$$

$$l_1y_2 = l \cdot \sin(\theta) = 248 \cdot \sin(45^\circ) = 175.36mm$$

$$B_{y1} = 175.36 + 175.36 = 350.7mm$$

After finding the final position coordinates, the change in angle can be found to find the angular velocity. The time used to find the velocity was measured by measuring the time it took to lift the arm from the side to the desired final position. After doing that several times the average time it took was 1.28 seconds.

$$\theta_1 = 163.3 - 45 = 118.6^\circ$$

$$\theta_2 = 0 + 45 = 45^\circ$$

$$\omega_1 = \frac{\Delta\theta_1}{1.28} = \frac{-2.01}{1.28} = -1.6171 \frac{rad}{s} \quad (6)$$

$$\omega_2 = \frac{\Delta\theta_2}{1.28} = \frac{\left(\frac{\pi}{4}\right)}{1.28} = 0.6136 \frac{rad}{s} \quad (7)$$

Finding the angular velocities, it shows that the max velocity will be 1.61 radians per second to keep it from moving too slow or too fast for the user. This will help gauge the speed that is selected when programming the speed of the motors.

4.3 Inverse Kinematics (Joel Gisleskog)

Inverse kinematics can be used to inform the motors which pitch/angle to be at for the end effector to reach a certain coordinate. This is the math that will be used to code the robotic arm to move in the correct way when the sensors have informed the motors of the intended position.

To start, define that the arm cannot have a negative position, the range wanted is moving the arm straight up and straight outward from the rest position. That is the range of motion that is being used in the project.

$$x \geq 0, y \geq 0, z \geq 0$$

$$x^2 + y^2 + z^2 \leq R^2$$

After defining the workspace constraints, the target point is limited to the region in front and above the base.

$$R_y(+)(\theta_1) = \begin{pmatrix} \cos(\theta) & 0 & -\sin(\theta) & 0 \\ 0 & 1 & 0 & 0 \\ \sin(\theta) & 0 & \cos(\theta) & 0 \\ 0 & 0 & 0 & 1 \end{pmatrix}$$

$$T_x(L) = \begin{pmatrix} 1 & 0 & 0 & L \\ 0 & 1 & 0 & 0 \\ 0 & 0 & 1 & 0 \\ 0 & 0 & 0 & 1 \end{pmatrix}$$

To describe the arm mathematically, transformation matrices are used. Each joint rotation is represented with a rotation matrix, and each link length is represented by a translation matrix. These matrices are combined to form an equation for forward kinematics.

$$FK = T_0^2 = R_z(\varphi)R_y(+)(\theta_1) T_x(L) R_y(+)(\theta_2) T_x(L)$$

Although the forward kinematics equation calculates (x,y,z) from known joint angles, inverse kinematics solves the opposite problem by calculating the required joint angles to reach a target coordinate.

$$x, y, z = (200, 180, 150) \text{ mm}$$

A target coordinate is chosen to test inverse kinematics solutions. First, the distance from the base to the target point is calculated to confirm the coordinate is within reach of the arm.

$$d = \sqrt{(200^2 + 180^2 + 150^2)} \approx 308 \text{ mm} \leq 496 \text{ mm}$$

In reach so this is okay, base rotation calculated using:

$$\varphi = \text{atan2}(y, x) = \text{atan2}(180, 200) \approx 41.99^\circ$$

This rotation aligns the target with the arms plane of motion, reducing the inverse kinematics to a 2D problem in the r-z plane.

$$r = \sqrt{x^2 + y^2}$$

Horizontal distance r is calculated using the equation above converting the target point to a 2D coordinate (r,z). The straight-line distance d from the waist to the target is calculated using:

$$d = \sqrt{r^2 + z^2}$$

Using the cosine rule θ_2 is found from the triangle formed by the two link lengths:

$$\cos(\theta_2) = \frac{d^2 - L^2 - L^2}{2L^2}$$

$$\alpha = \text{atan2}(z, r)$$

$$\beta = \text{atan2}(L \sin(\theta_2) + L \cos(\theta_2))$$

$$\theta_1 = \alpha - \beta$$

The angles α and β are used to find θ_1

$$\theta_1 = \text{angle of link 1}$$

$$\theta_2 = \text{angle of link 2}$$

$$\varphi = 41.99^\circ$$

$$\theta_1 = -22.47^\circ$$

$$\theta_2 = 103.21^\circ$$

4.4 Factor of Safety Table and SolidWorks FEA (Caleb Lamca)

To determine the stresses, present in each component of the robotic arm, finite element analysis (FEA) simulations were performed in SolidWorks. The forces were calculated in each component of the arm at the maximum load case, when the arm of the user is fully extended to one's side. This orientation would bear the full weight of the user's arm, causing a maximum moment around the base, and subsequently, at each component. The governing equations for these calculations can be found below.

$$M = F \times r$$

$$F = \frac{M}{r}$$

The moment equation is how the torque applied at each link was calculated. The manipulation of that equation allows for the torque to be converted into an applied force around the individual components' axis of rotation for the SolidWorks simulation. The weight of the arm used in these calculations also used the maximum load case using a hypothetical arm of a 100 kg male. Using standard anthropometry, we can assume that the weight of the arm is roughly 5.7% of the total body weight. Treating the arm as a simply supported beam with the load equally distributed between the elbow and shoulder, the resulting downward force at the point of contact with the robotic arm cuff is 3 kg. A table was created to summarize the complete FEA setup, and parameters can be found in the appendix as entry a, a table that summarizes the additional applied moment due to the weight of the user's arm in entry b, and a final setup table that provides the equivalent force due to the moment for each component in entry c. Several assumptions were made in the FEA setup. Notably, the hinge and motor assemblies at the hip were neglected because their small distance from the center of rotation results in combined moments that are orders of magnitude smaller than those of the primary system and therefore have a negligible effect on the overall response. Below is the factor of safety table created as a result of running the SolidWorks FEA Simulations using these parameters. [6]

Factor of Safety Table from Simulated FEA						
Sub-System	Part No.	Load Case Scenario	Description	Material	Method for Calculating FoS	Minimum FoS

	R3-DET001	0.435 [Nm] applied torque from upstream components	Link	Machined Carbon	Solidworks FEA	930
	R3-DET001	0.737 [Nm] applied torque from upstream components	Link	Machined Carbon	Solidworks FEA	549.5
	R3-DET002	0.428 [Nm] applied torque from upstream components	Mount 1	ONYX	Solidworks FEA	153.89
	R3-DET003	0.665 [Nm] applied torque from upstream components	Mount1- 2	ONYX	Solidworks FEA	43.14
	R3-DET004	0.438 [Nm] applied torque from upstream components	Mount 2	6061-T6	Solidworks FEA	848.4
	R3-DET005	N/A	Fastener Plate	Machined Carbon	N/A	-
	R3-DET005	0.428 [Nm] applied torque from upstream components	Fastener Plate	Machined Carbon	Solidworks FEA	122.5
	R3-DET006-V1	N/A	Motor Mount	ONYX	N/A	-
	R3-DET006-V1	0.432 [Nm] applied torque from upstream components	Motor Mount	ONYX	Solidworks FEA	13.57
SUB01-V1						
	R3-SUB01-DET001	-	Hinge Bracket	316L SS	Not Yet Calculated	-
	R3-SUB01-DET002	-	Hinge Block	6061-T6	Not Yet Calculated	-
	R3-SUB01-DET003	-	Hinge Cam	6061-T6	Not Yet Calculated	-
SUB02						
	Motor	N/A	Motor at Joint 1	N/A	N/A	N/A
	Motor	N/A	Motor at Joint 2	N/A	N/A	N/A
SUB03						
	R3-SUB03-DET001	-	Attachment from Hinge to Link	ONYX	Not Yet Calculated	-

	R3-SUB03-DET002	-	Attachment from Cuff to Hinge	ONYX	Not Yet Calculated	-
	R3-SUB03-DET003	-	Arm Cuff	Thermo Plastic	Not Yet Calculated	-

Figure 3: Factor of Safety Table

Details 5 and 6 have two entries but only one factor of safety to reduce redundancy. These are identical components, but the FEA was performed on the component with a higher load, and therefore, a smaller factor of safety. This is demonstrated in detail 1, with the two links carrying different loads and drastically different factors of safety. Please note that some of the components in the FoS table have not been tested using FEA at this point due to time constraints. The team recently redesigned the robotic arm and is in the process of gathering the data needed to run more tests. The remaining FEA simulations will be completed by Friday, January 30th. Updates will be presented during the 33% build progress report presentation.

4.5 Velocity for shoulder flexion at the elbow (Kaitlyn Davis)

Velocity of the arm at the elbow when the shoulder is undergoing forward flexion, where the arm starts from hanging straight down at 0 degrees and moves upward to a 90-degree angle. Here, the velocity of the arm at the elbow is observed and calculated using an average amount of time recorded by the team and known lengths of an average adult arm.

According to research, the average shoulder to elbow length is about 330mm (13in) in an adult. Shown below is the angular velocity equation:

$$w_{avg} = \frac{\Delta\theta}{t}$$

To reach 90 degrees from shoulder flexion (delta theta = 90 degrees) it took 1.28 seconds. We plugged our known values into the equation below.

$$w_{avg} = \frac{\Delta\theta}{t} = \frac{\left(90^\circ \cdot \left(\frac{\pi}{180}\right)\right)}{1.28 \text{ s}} = 1.227 \frac{\text{rad}}{\text{s}}$$

The average angular velocity of the arm from 0 to 90 degrees can be determined to be

around 1.227rad/s. The linear velocity of the elbow can be solved by using the equation below. For the radius r value, 330mm = 0.33m is used, because the velocity of the elbow is being solved.

$$v = w_{avg} \cdot r = 1.227 \frac{rad}{s} \cdot 0.33m = 0.405 \frac{m}{s}$$

Our results show that the velocity of our arm design needs to move around 0.405 m/s for safety and comfort when the device needs to move upward and downward.

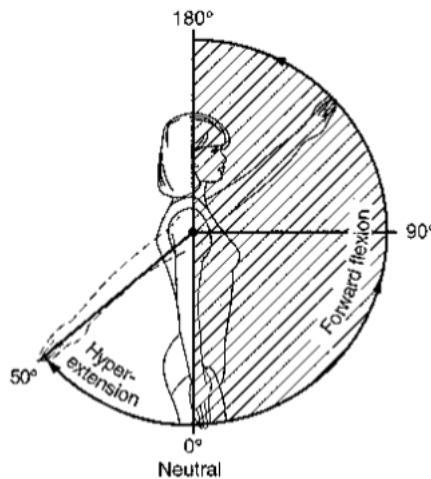

Figure 4: Anthropometry of Range of Motion

Determining Maximum Torque required (Cole Pace)

Using the angular velocity from the previous calculations, the required torque at the hip was calculated as follows:

$$\begin{aligned} \tau_H &= g \left(m_1 r_1 + (m_2 + m_{m2})(L_2 + r_2) + m_p(L_1 + L_2) \right) \\ &\quad + \alpha_1 \left(m_1 r_1^2 + m_2(L_2 + r_2)^2 + m_p(L_1 + L_2)^2 \right) \\ \tau_H &= 11.5 \text{ N} \cdot \text{m} \end{aligned}$$

With the max torque determined, we were able to select the motor that meets our requirements.

5.0 Moving Forward

All calculations that have been done will help inform the group about how to go about making decisions for the project. Most calculations may need to be altered as the design of the project is not yet finalized while the group is meeting with the client to receive input on the design. The runtime calculation can be adjusted by changing the number of batteries connected in parallel. This would also improve the continuous runtime that the arm would have. The link position is still useful in the projects' scope and can easily be recalculated if the length of the link is changed moving forward in the design process. The inverse kinematics will need to be expanded so that it can be fully and better understood when programming starts. The biggest calculations that must be improved are the finite element analysis of the design. This is due to the design being worked on with the client so that the overall design is what the client had envisioned. The calculations that are not done in the finite element analysis will be done once the redesign is complete, which will be done in the coming days after this report is due. There are still a lot of calculations to be done with several calculations from last semester that are no longer relevant with the design changes that were made at the request of the client. The team is confident that they will be done and will be able to design and create a product that meets the standards wanted by the client and professor.

6.0 Citations

- [1] World Health Organization, *WHO Standards for Prosthetics and Orthotics*, Geneva, Switzerland: World Health Organization, 2017.
<https://iris.who.int/server/api/core/bitstreams/0288426b-1f89-4fc8-ab83-a653107a657e/content>
- [2] “21 CFR Part 890 Subpart D -- Physical Medicine Prosthetic Devices,” *E CFR.gov*, 2015.
<https://www.ecfr.gov/current/title-21/chapter-I/subchapter-H/part-890/subpart-D>
- [3] Part 1_17164, “Prosthetics for Orthotics Standards & Implementation Guide,” Section C, Assessing Design Input Requirements for Adequacy, 1997.
- [4] Part 1_17164, “Prosthetics for Orthotics Standards & Implementation Guide,” Section C, Quantitative Limits with Measurement Tolerance, 1997.
- [5] U.S. Food and Drug Administration, “Medical Device Safety: Electrical and Electromagnetic Compatibility,” Guidance for Industry and FDA Staff, Oct. 2017. [Online]. Available: <https://www.fda.gov/media/xxxx/download>
- [6] U.S. Food and Drug Administration, “General Principles of Software Validation; Final Guidance for Industry and FDA Staff,” Jan. 2002. [Online]. Available: <https://www.fda.gov/media/73141/download>
- [7] ACP Composites, “Mechanical Properties of Carbon Fiber Composite Materials,” *ACP Composites*, Dec. 2023. [Online]. Available: <https://acpcomposites.com/wp-content/uploads/2023/12/Mechanical-Properties-of-Carbon-Fiber-Composite-Materials.pdf>.

	R3-SUB0 1-DET00 1	Hinge Bracket	316L SS	86	-	-	-	-	-	-
	R3-SUB0 1-DET00 2	Hinge Block	6061-T6	15	-	-	-	-	-	-
	R3-SUB0 1-DET00 3	Hinge Cam	6061-T6	16	-	-	-	-	-	-
SUB0 2									-	
	Motor	Motor at Joint 1		340	280	-	522700	-	522700	0.5227
	Motor	Motor at Joint 2		340	-	-	-	-	-	-
SUB0 3									-	
	R3-SUB0 3-DET00 1	Attachment from Hinge to Link	ONYX	46	570	290	26220	165300	191520	0.19152
	R3-SUB0 3-DET00 2	Attachment from Cuff to Hinge	ONYX	20	570	290	11400	165300	176700	0.1767
	R3-SUB0 3-DET00 3	Arm Cuff	Thermoplastic	-	-	-	-	-	-	-

b. Additional Moment Table

Mass of User's Arm [g]	Distance from End Effector to Joint 1	Distance from End Effector to Joint 2	Moment Additional to Components at Joint 1 [g*mm]	Moment Additional to Components at Joint 2 [g*mm]
3000	570	290	427500	217500

c. FEA Setup Table

FEA Setup/Parameters						
Sub-System	Part No.	Description	Material	Total Moment at this Component [N*m]	Radius from Center of Rotation [m]	Equivalent Force [N]
	R3-DET001	Link	Machined Carbon	0.43485	0.15	2.899
	R3-DET001	Link	Machined Carbon	0.73696	0.15	4.913066667
	R3-DET002	Mount 1	ONYX	0.4279	0.064	6.6859375
	R3-DET003	Mount1- 2	ONYX	0.66484	0.053	12.54415094
	R3-DET004	Mount 2	6061-T6	0.43814	0.015	29.20933333
	R3-DET005	Fastener Plate	Machined Carbon	-	-	-
	R3-DET005	Fastener Plate	Machined Carbon	0.42834	0.03	14.278
	R3-DET006-V1	Motor Mount	ONYX	-	-	-
	R3-DET006-V1	Motor Mount	ONYX	0.43198	0.03	14.39933333
SUB01-V1						
	R3-SUB01-DET001	Hinge Bracket	316L SS	-	-	-
	R3-SUB01-DET002	Hinge Block	6061-T6	-	-	-
	R3-SUB01-DET003	Hinge Cam	6061-T6	-	-	-
SUB02						

	Motor	Motor at Joint 1		0.5227		-
	Motor	Motor at Joint 2		-	-	-
SUB03						
	R3-SUB03-DET001	Attachment from Hinge to Link	ONYX	0.19152	0.022	8.705454545
	R3-SUB03-DET002	Attachment from Cuff to Hinge	ONYX	0.1767	0.015	11.78
	R3-SUB03-DET003	Arm Cuff	Thermo Plastic	-	-	-

d. Evidence of Performed FEA (In order of part number/table setup)

i. DET001 (Link) FEA with 1st Load Case

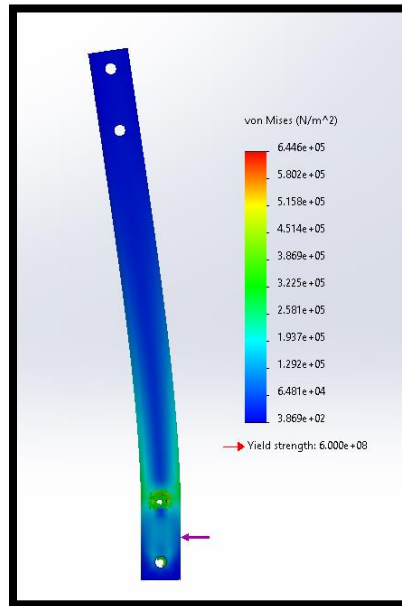

ii. DET001 (Link) FEA with 2nd Load Case

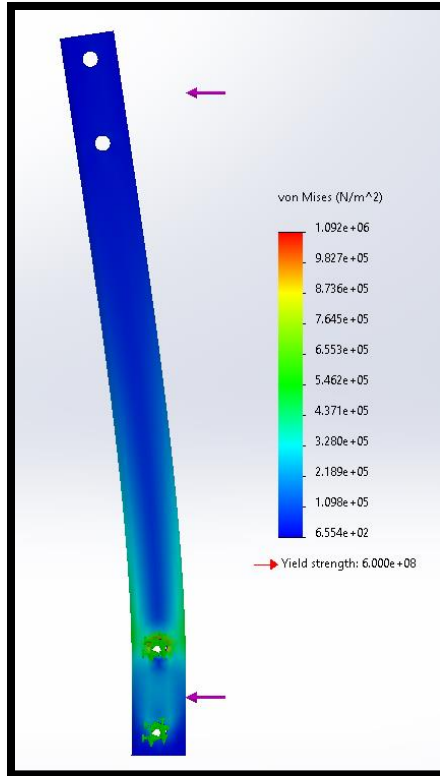

iii. DET002 (Mount 1) FEA

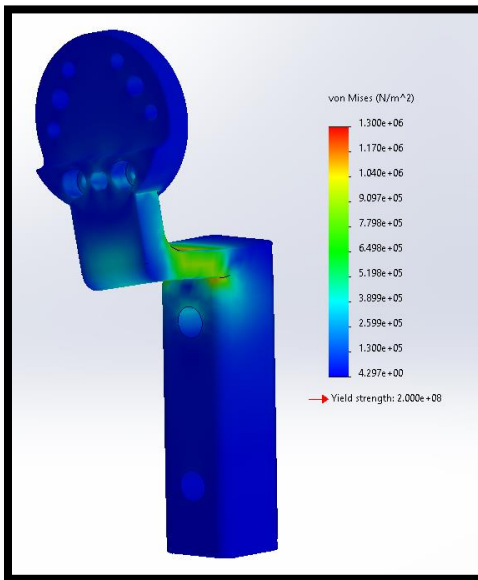

iv. DET003 (Mount 1-2) FEA

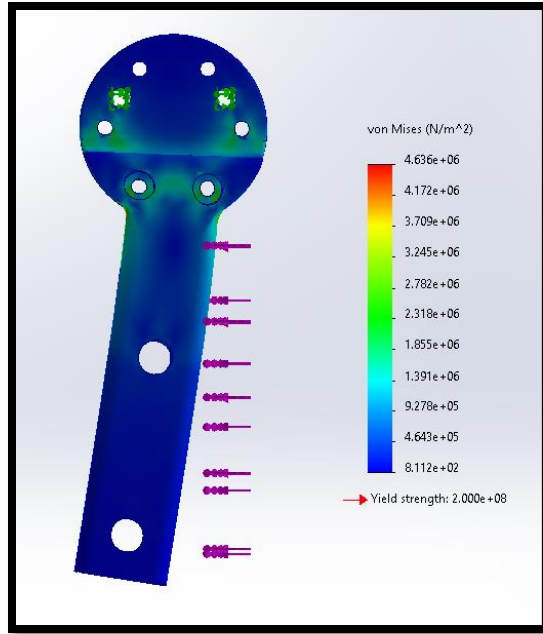

v. DET004 (Mount 2) FEA

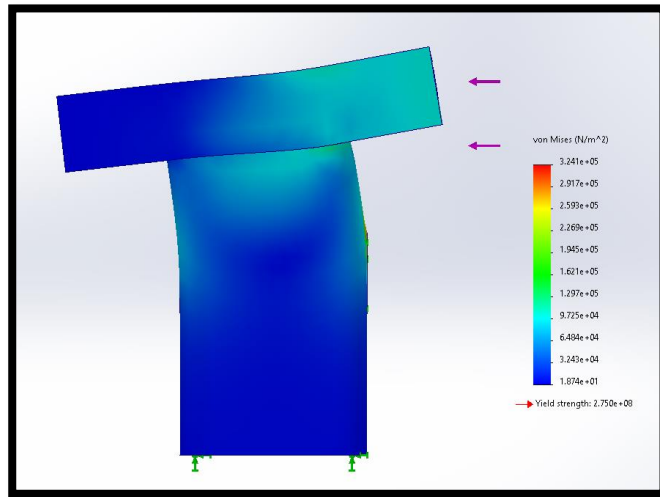

vi. DET005 with Maximum Load Case

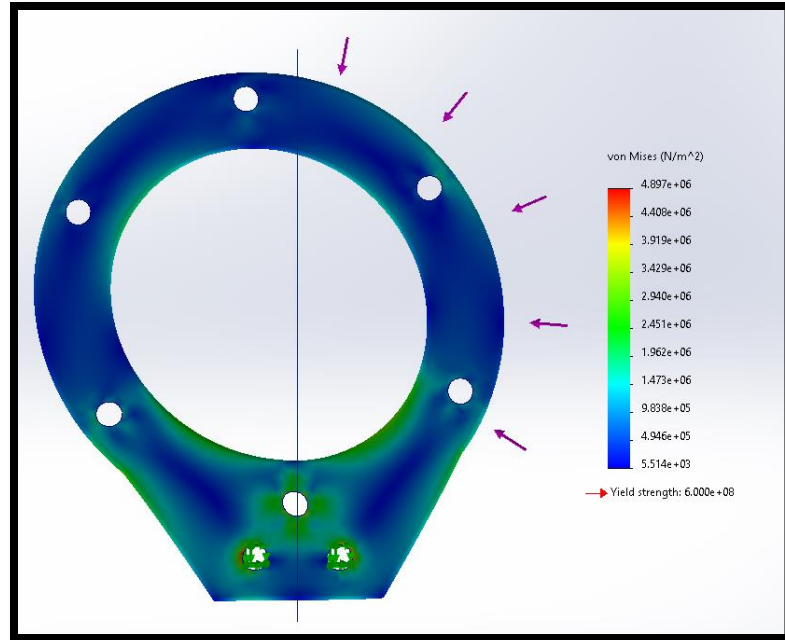

vii. DET 006 with Maximum Load Case

